

MetaCAM

Leading the Industry with Innovative CAD/CAM Solutions

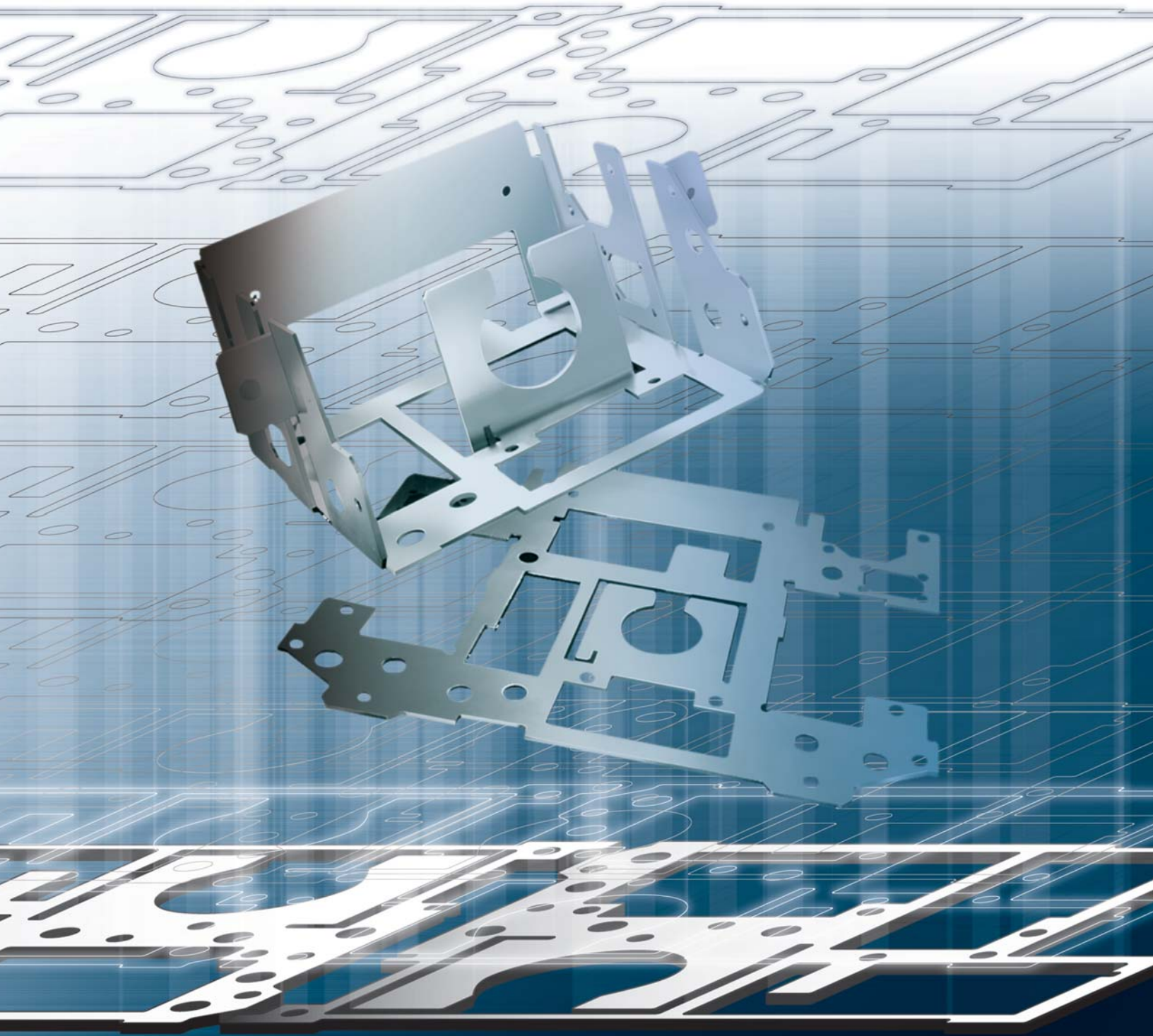

 **Metamation, Inc.**

2D CAD

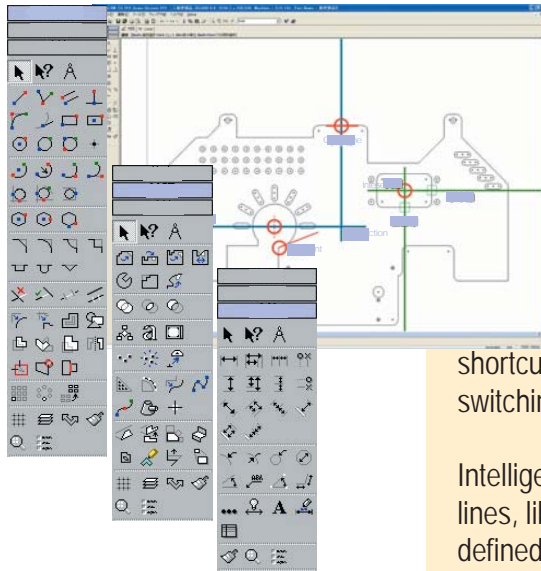

MetaCAM's easy to use and powerful drafting system helps you breeze through part creation. Each drawing icon is designed to morph into several operations using

shortcuts that eliminate troublesome switching between icons.

Intelligent Snaps, Automatic construction lines, library of canned shapes and user defined parametrics are just a few of the many powerful CAD functions in MetaCAM.

Highlights:

- Supports blocks, layers and spline curves.
- Automatic Dimensioning of Parts.
- Imports drawings from DXF, DWG, IGES or PRT files.
- Parametric Transitions and Duct unfold.
- Solidedge © and Solidworks © Import.
- Flat to 3D model fold up capability.
- Common Shape Array Tool.
- Clean up Splines, Duplicate, and Open geometry.
- Supports Etch and Engraving Layers that can be tooled when programmed.
- Easily unfold 3D models to 3view shop shop floor drawings.

3D CAD

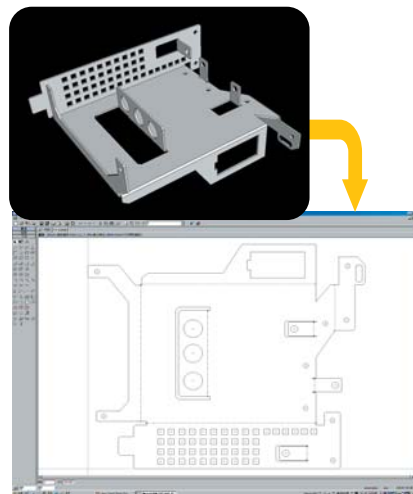

MetaCAM's 3D sheetmetal modeler can.....

- Read IGES, STEP, Solidedge © and Solidworks © native 3D models.
- Easily switch between Bend and Cut Edges.
- Unfold 3D models into Flat patterns directly ready for CAM.
- Represent form shapes such as Louvers, Lances, Countersinks and automatically assign Tooling.
- Automatically create Boxes, Mitered Corners.
- Model and Unfold weld & hemming flanges.

LASER / PROFILE CAM

Leaders in Profile Cutting.

MetaCAM's engine for laser, plasma, router and water-jet machines helps you get the most out of profile cutting machines. Sophisticated technology tables optimize machine parameters after analyzing parts.

Highlights:

- Unparalleled support for special machines.
- Sophisticated algorithms handle traverse-line routing for even the most complicated parts.
- Punch-laser hybrid machines support.
- Optimally divides the processing between punch and laser in hybrid machines.
- Automatically assign Lead-in, Escape Geometry based on part size and thickness of material.
- Support Multiple Pierce Types and Cut Conditions to exploit machine specific features.

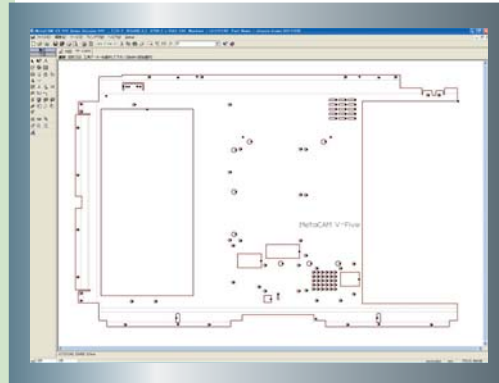

Laser Auto Tool

Conditions required for various Laser CAM processes can be specified in the Part Settings Dialog (Approach Point, Escape Geometry, Joints, Pierce types, Corner Loop Types, work - chute). Conventional operations that manually controlled these parameters are no longer necessary - they are all completely automated.

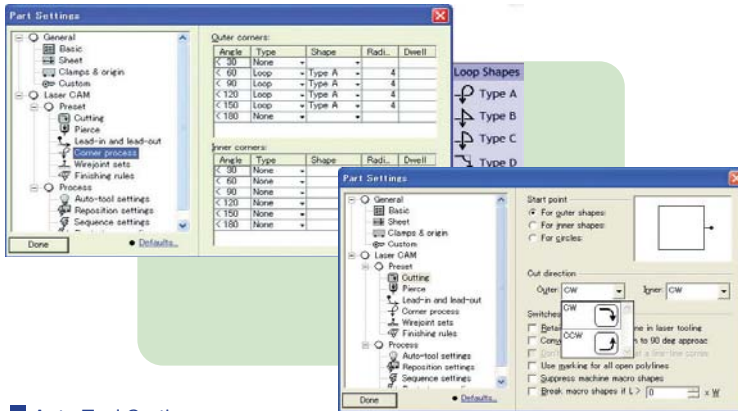

Auto Tool Sorting

Operations such as Optimization, routing of traverse lines, repositioning are all bundled into single auto sequence operation.

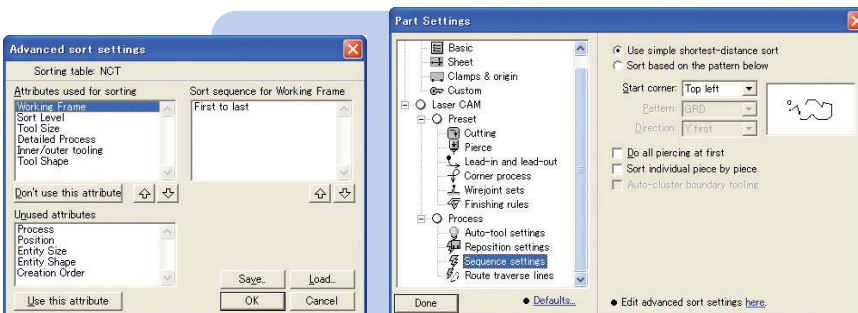

Laser Cutting Database

MetaCAM provides an extensive database to control various aspects of laser tooling, such as cut conditions, pierce conditions, approach and escape settings.

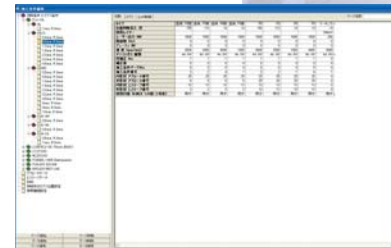

Time Study

MetaCAM provides a detailed time study that displays the total time along with information such as the total length of cut, traverse time, part weight and number of pierces.

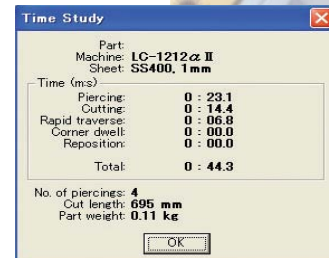

Punch CAM

Unparalleled Productivity for Turret Presses

Auto Tool Function

Auto Tooling is done based on large set of parameters and tooling guidelines. Tooling Patterns, Nibble Pitch, Tool Overlap, Tool Size Tolerance etc. can be controlled and automated through the tooling process.

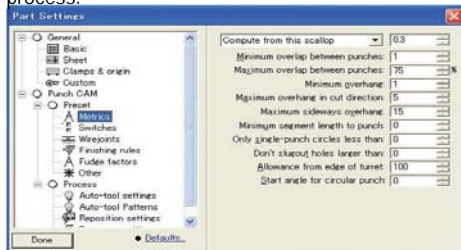

Punch Auto-tooling dialog

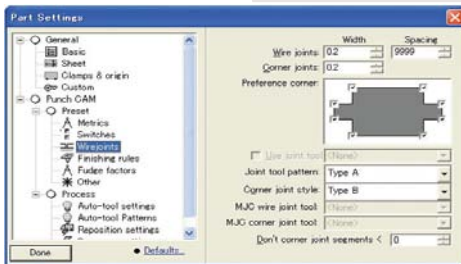

Tool Library

Standard, Special, Forming, and Custom tools can be created, maintained, and synced using the MetaCAM Tool Library. Graphical Turrets with a true representation of the actual machine turret is a standard feature. Tools can be loaded using drag-and-drop feature. Multiple turrets can be stored for each machine and reports printed to review tool lists.

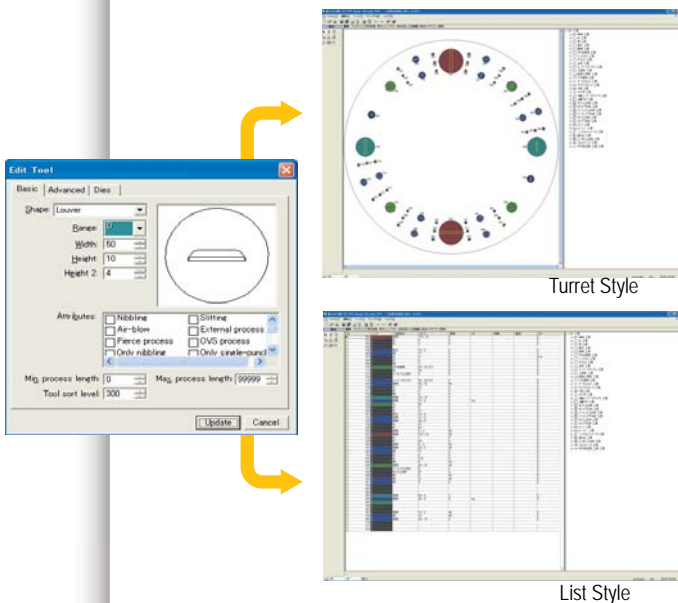

Auto Sequence

MetaCAM allows you to sequence the tooling of the part for generating NC code. Table and Interactive Sequence help you to graphically verify the tooling sequence.

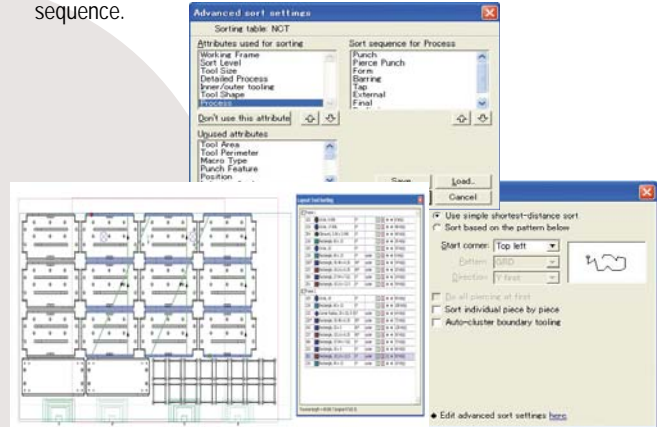

Priority Driven Auto Tooling

Auto Tooling Patterns are all priority driven and subdivided based on tool shape, hole size and tool type. You can also select the pattern of your choice graphically.

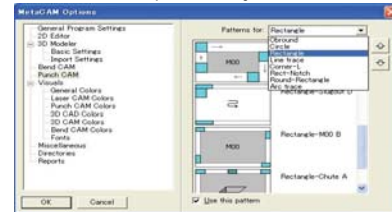

Highlights

- Sophisticated Auto Tooling Engine minimizes manual intervention.
- Color Coded Graphical Turret and Tool Library for easy operation.
- Automatic Assignment of Wirejoints and Cornerjoints based on size of part
- Automatic Chute Assignment
- Support for Custom Shape Tools and Form Tools
- Automatic Sequencing and Repositioning generates NC code in one operation
- Table Sequencing provides graphical display and easy editing to sheet wide sequence.
- Supports Multiple Tool Libraries and Tool Collections based on make and model of tooling.

Nesting

**Free Shape Geometry Nesting delivers
Excellent Material Efficiency**

MetaCAM's Nesting Engine has a pallet of nesting algorithms to suit different needs. The tight integration with MetaCAM offers benefits that third party nesting engines can never match. Reading Parts, the nesting engine can directly generate nested sheets and greatly simplify workflow.

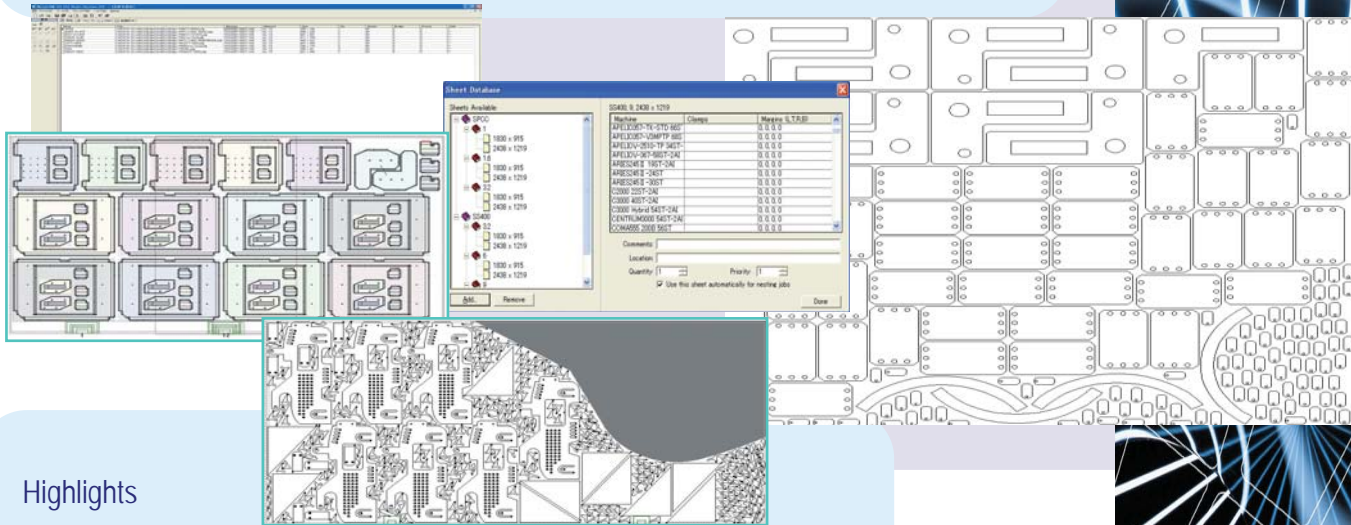

Highlights

- Maximize Material Utilization and Reduce Programming Time.
- Go From 1000 job orders to nested NC programs in minutes.
- Algorithms for Common Line Cutting, Part-in-Part, Right Angle Shear and Nest Around Clamps
- In the event of mechanical machine issues, easily re-nest parts for a different machine.
- Automatic Turret Conflict Resolution to build a single nest turret.
- Reduce Cutting and Shearing Time with Common Line Nesting.

MRP Integration and Automation

The Metaworks AI and AutoCAM modules from Metamation, Inc is the latest product developed to further improve productivity from your MetaCAM software. Using this software, users can batch program and auto nest parts with just a few clicks. Just select a material and point to the folder where your CAD files are stored, let the software do the rest—

Metaworks can.....

- Import, Tool up and program a parts in less than 5 secs.
- Automatically load an MRP feed to nesting at about one sec a part.
- AutoNest and Generate ready to run NC code based on the MRP schedule for the day/week/month.



MetaBEND

3d Bend Simulation and Programming

Auto Tooling

Once the desired bend machine is selected, the auto tooler assigns suitable tooling based on the 3D model to generate a collision free bend sequence. The Bend Sequence and Tooling Layout can be output on graphical reports.

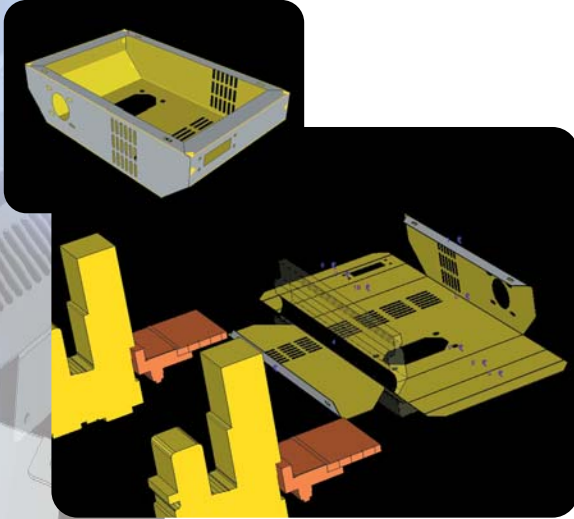

Collision Check and Simulation

The Bend Simulator provides detailed, precise, and configurable simulation of the entire operation. Back gauge movement, ram stroke, part insertion, and retraction are all animated. Simulation checks for collision between parts, tools, punch holder, and machine - displays any such collisions found in the model. Collisions can be visually inspected, zoomed in, and corrected using the graphical interface.

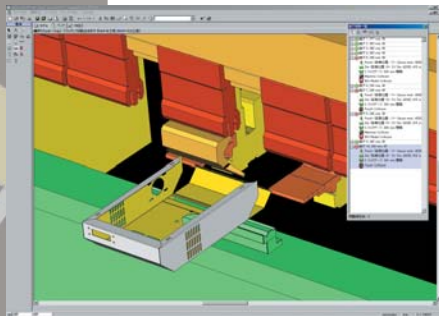

Tool layout & Bend Reports

Tool Mount Position, Tool Flip etc. can be modified similar to the actual machine operation. Detailed Bend Reports can be generated with 3D views of each Bend.

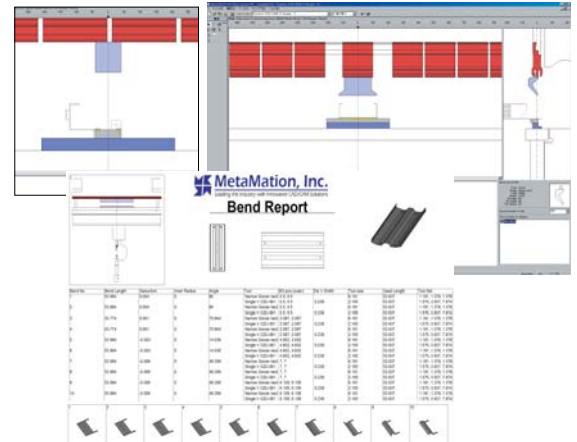

Back gauge editing

You can view the back gauges graphically and also change the position of the back gauges in the 3D visual representation window.

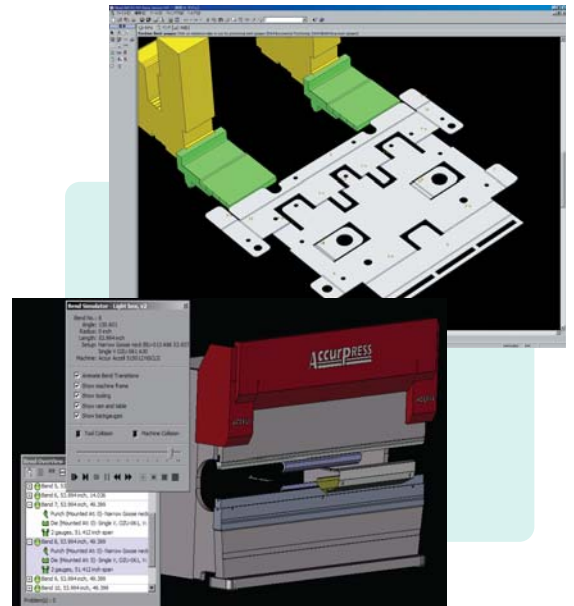

Highlights

- Full 3D Bend Simulation and Collision Checking.
- Collision Checking for safer operation of the press brake.
- Graphical reports provide the operator detailed step by step setups.
- Eliminate Scrap due to Trial and Error Programming.
- Safely store complex bend programs for reuse.
- Optimize tool selection to minimize changing setups.

MultiAxis & Rotary CAM

Powerful CAM system enables efficient multi axis machine operation

MetaCAM's rotary cutting module allows rotary axis programming for round, square and rectangular tubes. The Multiaxis programming module can program 3D curved surfaces which eliminates teach and playback

Highlights

- Holes can be arrayed, projected through and wrapped around tubes.
- Automatic Collision Checking warns the user of any machine collisions.
- Automatic / Interactive Sequencing of cuts.
- Automatic Fixture Creation based on the shape of the 3d model.
- Auto Export Fixture to 2D nesting and cut using a 2D laser.
- Add / Remove cutting vectors to smoothly cut out curved surfaces.

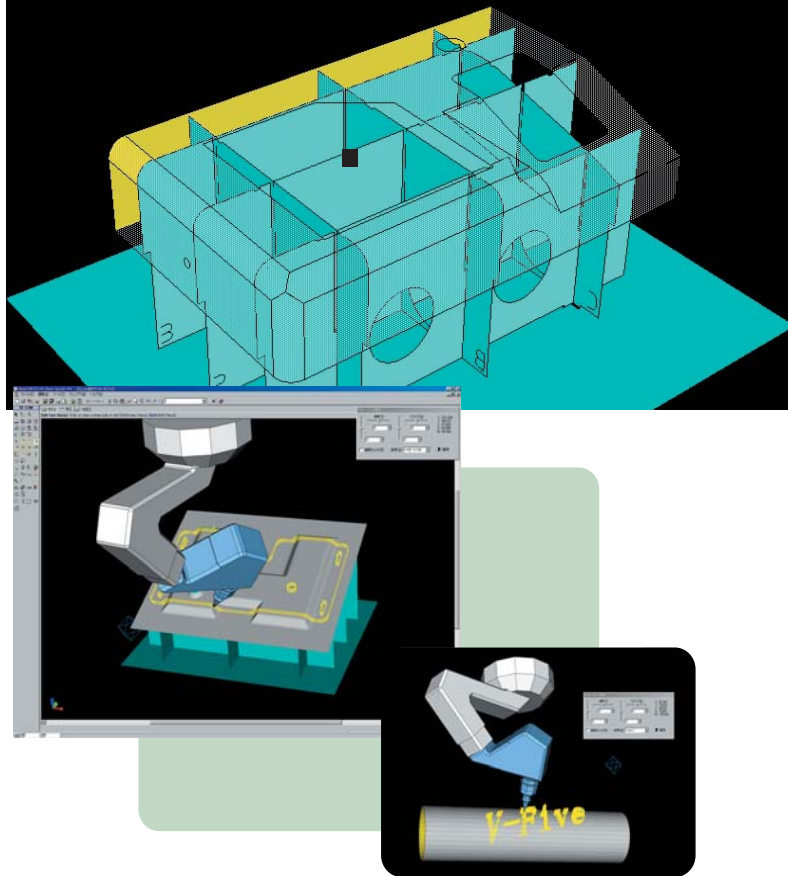

Reports

Customizable and Graphical Reports

MetaCAM has an integrated report designer that allows you to customize report formats per your requirements. The reports display graphical images of nests, parts, bend sequences along with machine specific information such as tool lists, clamp locations and sheet sizes. You can even add your company logo or bar code data to integrate with other shop floor systems.

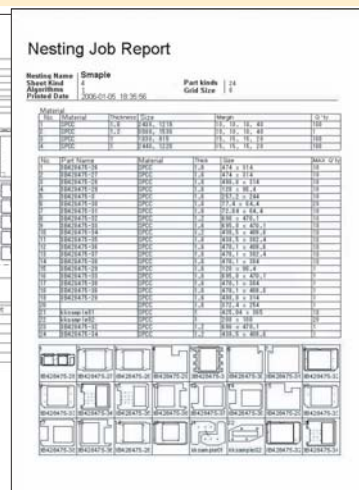
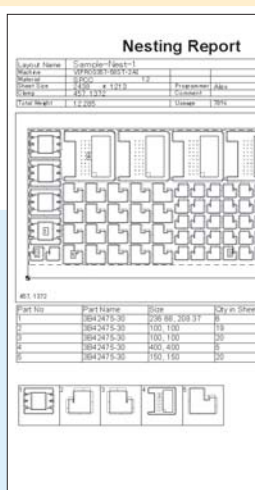
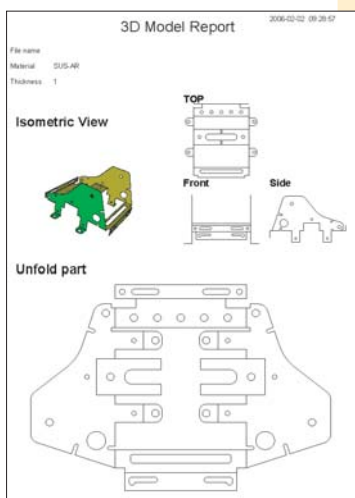

MetaCAM

Computer Specifications

Items	Contents	
OS		Windows-XP [®] or Windows 2000 [®]
CPU		Pentium III 1GHz or more
Memory		512MB or more
HDD capacity		40GB or more
CD-ROM		*1
Monitor		Recommended 17 inch or larger
Video Card		Resolution 1024x768 High color or more; Open GL support Recommended for 3D
Mouse		Microsoft [®] IntelliMouse
Part	Parallel	Printer port
	USB	*2
	Serial	*3
Backup drive		Recommended CD-RW or DVD-RW
Printer		Windows XP [®] , Windows 2000 [®] compatible

*1 Required to install MetaCAM.

*2 USB Port required if no Parallel port is available.

*3 Serial Port required for RS-232C (DNC) output.

* All Copyright and Trademarks are Property of their Respective Owners

 Metamation, Inc.

1698 Meadow Wood Lane

Ste 202

Reno, NV 89502

Ph : 775 826-1717

FAX: 775 826-1723

sales@metamation-us.com

www.metamation-us.com



Tel. 55 2121 9181
y 55 2121 9194

Soporte & Desarrollo
en Maquinaria