

ACCURPRESS

PRODUCT CATALOG





About Us

With over 45 years in the marketplace, Accurpress continues to build on its tested history to manufacture an innovative and complete line of press brakes and shears for every bending and shearing application. Proudly North American made, Accurpress leads the way with high tonnage machines, revolutionary pole bending technologies, tandem machines, and robot automation. With over 21,000 machines sold to thousands of satisfied customers, Accurpress continues to build press brakes and shears to meet the demands of today's manufacturing environments.

"While 45 years have brought huge changes to the machine tool industry, all of us at Accurpress continues to stand firm on the original foundation of quality that the company was built on. Every Accurpress machine, including the one you'll buy, is made with 100% of our best efforts. Our business depends on it and so does yours."

Steve Hilton
President

ACCELL H

60-190 Ton Models

The Accell H 120-190 ton models combine power and precision into a sleek design. Using a combination of Electric and Hydraulic Drive Systems, these hybrid machines are highly efficient, impressively quiet and utilize the latest in Accurpress Motion Technologies.



HYBRID MACHINES

ACCELL HU

120-190 Ton Models

The Accell H 120-190 ton models can be upgraded to The Accell HU Package. All of the features of the Accell H model are included, with the addition of upgraded machine covers, Vision drop-down screen and the 6-axis Supreme backgauge.



Reference www.accurpress.com for detailed information including our comprehensive brochures.

ACCELL E

75-500 Ton Models

The Accell H 120 - 190 ton models combine power and precision into a sleek design. Using a combination of Electric and Hydraulic Drive Systems, these hybrid machines are highly efficient, impressively quiet and utilize the latest in Accurpress Motion Technologies.

FEATURES

- 12"-14" Throat Depth
- Backgauge Options
- Y1/Y2 Proportional Hydraulic Technology
- Vision Controls
- Hydraulic Ram Clamping
- Generous Open Height/Stroke Length
- Off Center Bending
- CNC Crowning
- Front Support Arms



ACCELL U Upgrade Package

90-550 Ton Models

The Accell U Upgrade Package builds on the already impressive standard features of the Accell E machine to provide even more functionality and flexibility. This specialized machine can handle any forming challenge or production run with ease.

FEATURES

- 16"-18" Throat Depth
- Double Bending Speed
- Control Screen Upgrade
- Optional ETS3000 Control
- Additional Stroke Lengths
- Four Point Roller Ways System
- Material Compensation Features
- Front Bed Machining for Optional Precision Sheets supports and/or Sheet Followers



Reference www.accurpress.com for detailed information including our comprehensive brochures.

ACCELL HT

650-3000 Ton Models

The standard features of the Accell HT combine technology and efficient material handling options to make big jobs easier to accomplish. All aspects of our High Tonnage machines are designed to be reliable, flexible, and perform in the most demanding conditions. These machines can also be customized for specific applications.

FEATURES

- Remote Hydraulics
- Titan Backgauge
- Y1/Y2 Proportional Hydraulic Technology
- Generous Open Height/Stroke Length
- Vision Controls
- Optional ETS3000 Control
- Ram Tool Clamping Options
- Optional Adjustable Power Lock Die



ADVANTAGE



250 Ton X 12 ft.

The Advantage Rocker Arm has stood the test of time with thousands of machines shipped all over North America. Offered in a wide range of available sizes from 25 tons to 3000 tons.

HIGH TONNAGE

Accurpress offers Rocker Arm machines up to 3000 tons and several options specifically designed for bending heavy plate. We can also custom engineer machines to fit exact specifications. Whatever forming challenges you have, we can design a machine to get it done.



2000 Ton X 24 ft.

Reference www.accurpress.com for detailed information including our comprehensive brochures.

ACCURSHEAR



The North American built Accurshear is a combination of simplicity and strong, proven design. This heavy-duty 1/2" cut capacity x 12' shear can tackle any application. Models range from 10 gauge x 6' all the way to 1" x 20'.

1/2" cut capacity x 12'

SHEAR AUTOMATION

The robust Accurshear CNC Frontgauge Table offers the most advanced precision system for gauging, including heavy-duty material grippers that drive the material to the preset dimensions.



TOOLING

Accurpress offers a complete line of press brake tooling that can handle all forming challenges: segmented precision tooling for quick tool changes and high accuracy forming, general purpose for complete length tooling and four-way dies and full custom tool design support. If you need something unique, all we need is a part drawing and we will take it from there!

Precision Line



General Purpose Line

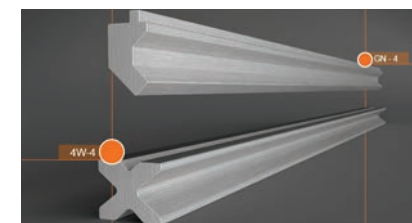

Special / Custom Tools Line



Accurpress also offers a full range of Adjustable Bottom Dies and Crowning Die Holders.

Heavy Duty Power-Lock Die

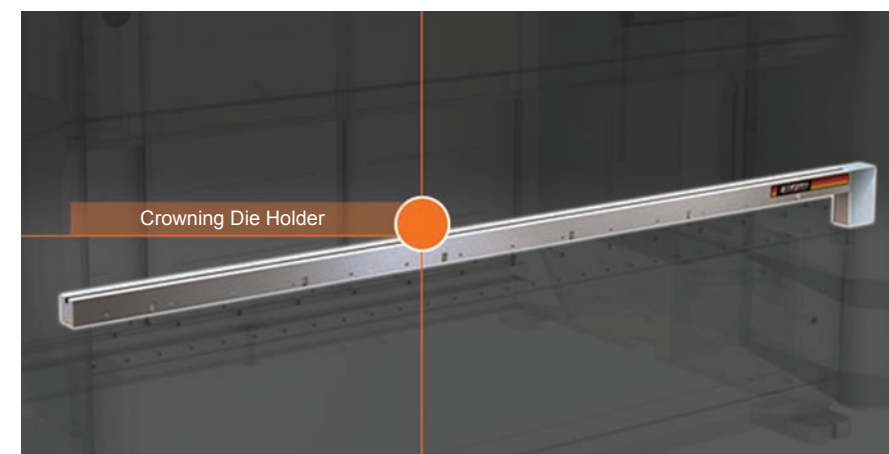
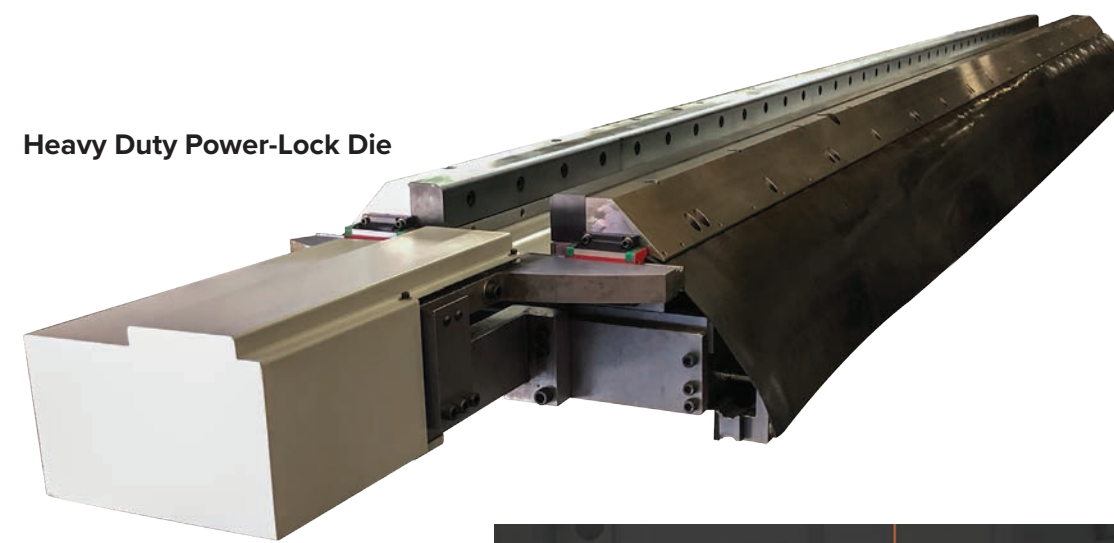

Reference www.accurpress.com for detailed information including our comprehensive brochures.

Dealer Support Network

Accurpress Sales & Service is provided by an Authorized Dealer Network. All of our Dealers are factory trained and supported to provide you with knowledgeable, competent, and local service.



© Copyright April 2020

For more information about our products, please refer to our comprehensive brochures or visit our site www accurpress.com.

ACCURPRESS



Tel. 55 2121 9181
y 55 2121 9194

Soporte & Desarrollo
en Maquinaria