

Accurpress Precision Forming Systems

# ACCUR<sup>S</sup>HEAR

SHEAR POWER

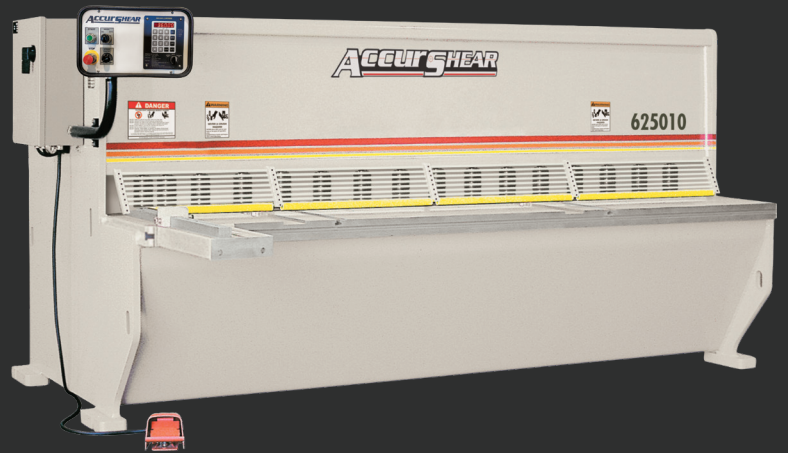

**ACCURPRESS**

ACCURPRESS

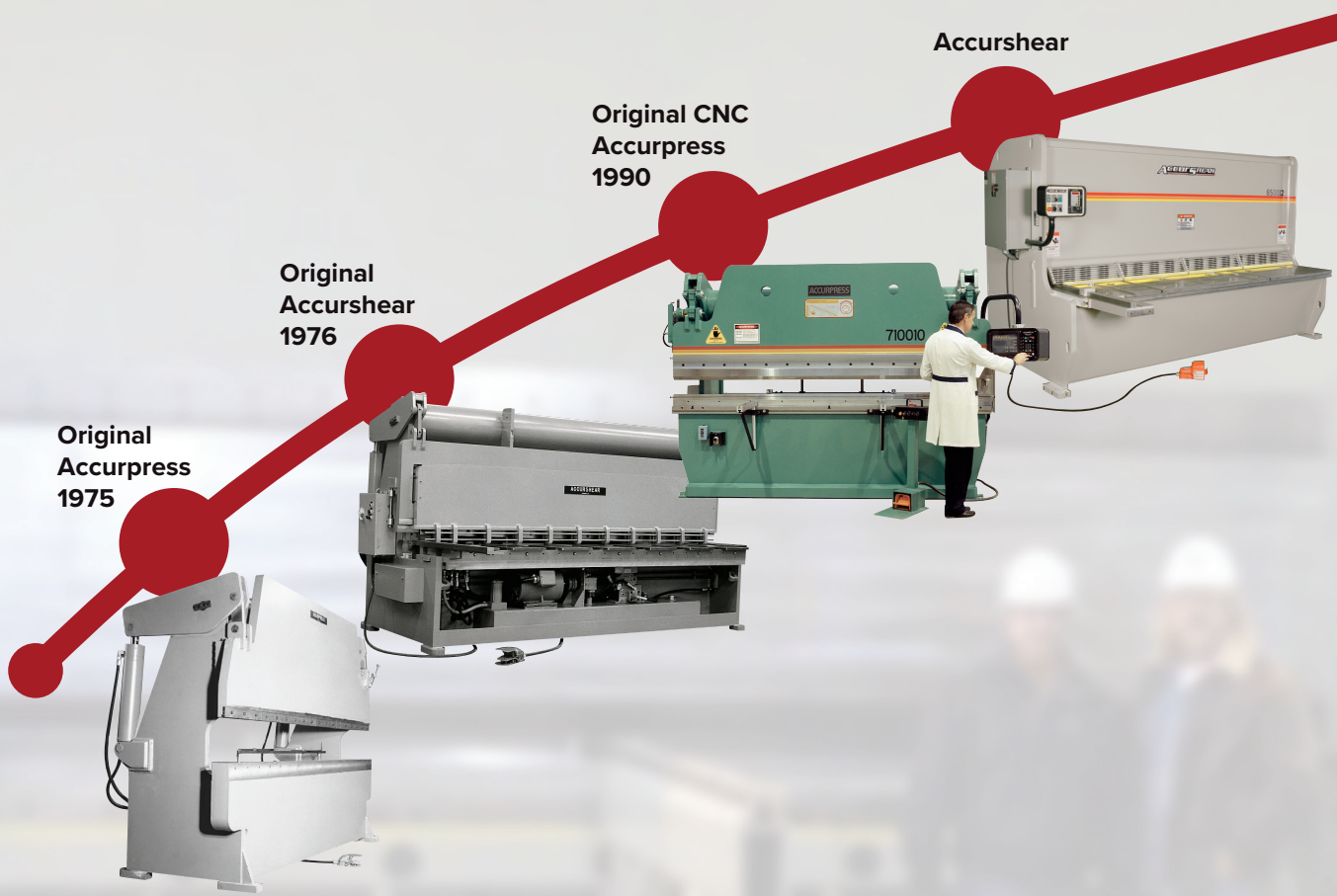



## About Us

With over 45 years in the marketplace, Accurpress continues to build on its tested history to manufacture an innovative and complete line of press brakes and shears for every bending and shearing application. Proudly North American made, Accurpress leads the way with high tonnage machines, revolutionary pole bending technologies, tandem machines, and robot automation. With over 21,000 machines sold to thousands of satisfied customers, Accurpress continues to build press brakes and shears to meet the demands of today's manufacturing environments.

“While 45 years have brought huge changes to the machine tool industry, all of us at Accurpress continues to stand firm on the original foundation of quality that the company was built on. Every Accurpress machine, including the one you'll buy, is made with 100% of our best efforts. Our business depends on it and so does yours.”

**Steve Hilton**  
President

## Accurshear 6135 SERIES

**10 GA. CAPACITY**



### Standard Features

- Shear capacity up to 80,000 tensile and 44,000 yield strength.
- Pendant control c/w on/off buttons, mode selector switch, and stroke control dial.
- Backgauge control includes LED display, inch or metric conversion, go-to-position function, 999 pre-select programs, hour meter and stroke counter.
- 36" backgauge travel with automatic swing up backstop at full extension.
- Mechanical Point of Operation Guarding applicable to OSHA and ANSI regulations.
- 4-edged blades, top, and bottom, modified high carbon, high chrome.
- 3 position footswitch control.
- 4' squaring arm c/w steel rule with 1/16" and 1 mm increments.
- Shadow light and line.
- Hand slots in table.
- Drilled and tapped holes in front of table.

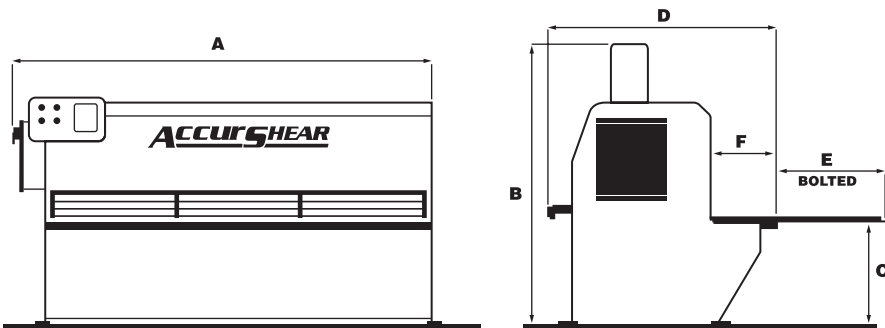

MODEL NUMBER	CAPACITY INCHES	LENGTH FEET	KNIFE SIZE INCHES	NUMBER OF HOLD DOWNS	HOLD DOWN TONNAGE	CYCLES PER MINUTE		OPTIONAL HI-SPEED		MOTOR H.P.	OVERALL DIMENSIONS						APPROX. WEIGHT LBS.
						FULL STROKE	SHORT STROKE	FULL STROKE	SHORT STROKE		A	B	C	D	E	F	
61356	10 ga	6	1x3x76	10	10	40	65	n/a	n/a	10	98	80	32	81	25	18	9,000
61358	10 ga	8	1x3x100	13	13	35	60	n/a	n/a	10	122	80	32	83	23	20	11,000
613510	10 ga	10	1x3x124	16	16	30	55	n/a	n/a	10	146	80	32	84	22	21	14,000
613512	10 ga	12	1x3x148	19	19	25	45	n/a	n/a	10	170	80	32	86	21	22	17,000
613514	10 ga	14	1x3x172	22	22	20	40	n/a	n/a	10	194	80	32	88	18	24	20,000

Specifications are subject to change without notice. Capacities are based on 80,000 tensile/44,000 yield strength steel.

# Accurshear 6250 SERIES

**1/4" CAPACITY**

## Standard Features

- Shear capacity up to 80,000 tensile and 44,000 yield strength.
- Pendant control c/w on/off buttons, mode selector switch, and stroke control dial.
- Backgauge control includes LED display, inch or metric conversion, go-to-position function, 999 pre-select programs, hour meter and stroke counter.
- 36" backgauge travel with automatic swing up backstop at full extension.
- Mechanical Point of Operation Guarding applicable to OSHA and ANSI regulations.
- 4-edged blades, top, and bottom, modified high carbon, high chrome.
- 3 position footswitch control.
- 4' squaring arm c/w steel rule with 1/16" and 1 mm increments.
- Manual quick blade clearance adjustment.
- Shadow light and line.
- Hand slots in table.
- T-slot in front of table.
- Oil cooler.

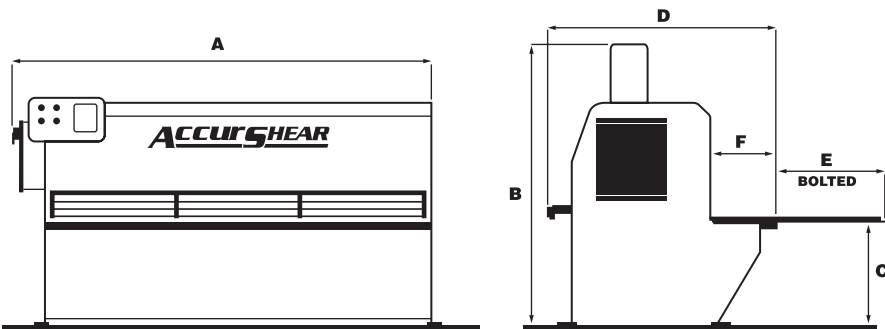

MODEL NUMBER	CAPACITY INCHES	LENGTH FEET	KNIFE SIZE INCHES	NUMBER OF HOLD DOWNS	HOLD DOWN TONNAGE	CYCLES PER MINUTE		OPTIONAL HI-SPEED		MOTOR H.P.	OVERALL DIMENSIONS						APPROX. WEIGHT LBS.
						FULL STROKE	SHORT STROKE	FULL STROKE	SHORT STROKE		A	B	C	D	E	F	
62506	1/4	6	1x3x76	10	10	30	55	46	65	20	99	83	32	82	25	18	11,000
62508	1/4	8	1x3x100	13	13	26	50	42	65	20	123	83	32	84	23	20	14,000
625010	1/4	10	1x3x124	16	16	23	48	38	60	20	147	83	32	85	21	22	17,000
625012	1/4	12	1x3x148	19	19	20	46	32	60	20	171	83	32	87	20	23	21,000
625014	1/4	14	1x3x172	22	22	17	42	26	55	20	195	89	33	90	18	25	32,000
625016	1/4	16	1x3x196	25	25	14	38	21	55	20	219	89	33	92	15	28	39,000
625018	1/4	18	1x3x220	28	28	13	34	19	55	20	243	94	33	94	13	30	47,000
625020	1/4	20	1x3x244	31	31	12	30	17	50	20	267	94	33	96	11	32	57,000
625024	1/4	24	1x3x268	37	31	10	26	14	50	20	291	96	33	98	9	34	88,000

Specifications are subject to change without notice. Capacities are based on 80,000 tensile/44,000 yield strength steel.

## Accurshear **6375** | **6500** SERIES

**3/8" 1/2" CAPACITY**

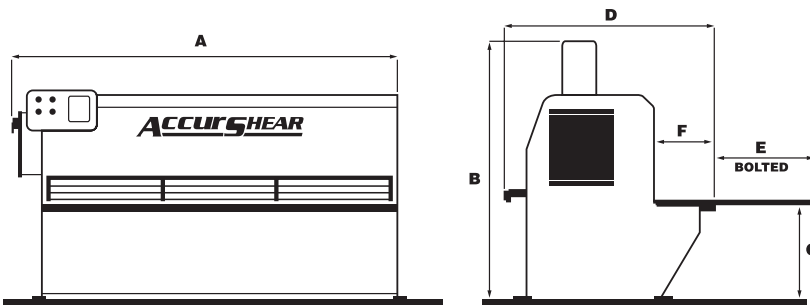

### Standard Features

- Shear capacity up to 80,000 tensile and 44,000 yield strength.
- Pendant control c/w on/off buttons, mode selector switch, and stroke control dial.
- Backgauge control includes LED display, inch or metric conversion, go-to-position function, 999 pre-select programs, hour meter and stroke counter.
- 36" backgauge travel with automatic swing up backstop at full extension.
- Mechanical Point of Operation Guarding applicable to OSHA and ANSI regulations.
- 4-edged blades, top, and bottom, modified high carbon, high chrome.
- 3 position footswitch control.
- 4' squaring arm c/w steel rule with 1/16" and 1 mm increments.
- Manual quick blade clearance adjustment on 63756 through 650012 models
- Power blade clearance on 650014 and larger models.
- Shadow light and line.
- Hand slots in table.
- T-slot in front of table
- Ball transfers in table for 6500 Series (optional for 6375 Series).
- Oil cooler.

MODEL NUMBER	CAPACITY INCHES	LENGTH FEET	KNIFE SIZE INCHES	NUMBER OF HOLD DOWNS	HOLD DOWN TONNAGE	CYCLES PER MINUTE		OPTIONAL HI-SPEED		MOTOR H.P.	OVERALL DIMENSIONS						APPROX. WEIGHT LBS.
						FULL STROKE	SHORT STROKE	FULL STROKE	SHORT STROKE		A	B	C	D	E	F	
63756	3/8	6	1x3x76	10	11	26	46	33	55	30	100	88	32	85	22	21	16,000
63758	3/8	8	1x3x100	13	13	24	46	31	55	30	124	88	32	85	22	21	19,000
637510	3/8	10	1x3x124	16	16	21	44	29	50	30	148	88	32	87	20	23	21,000
637512	3/8	12	1x3x148	19	19	18	40	26	46	30	172	90	33	90	17	26	27,500
637514	3/8	14	1x3x172	22	22	15	36	23	40	30	196	90	33	95	12	31	36,000
637516	3/8	16	1x3x196	25	25	13	33	20	38	30	221	91	34	95	12	31	45,000
637520	3/8	20	1x3x244	31	31	11	25	16	28	30	269	93	36	96	11	32	71,000
65006	1/2	6	1x4x76	10	12	21	42	26	48	40	102	97	34	88	20	22	19,000
65008	1/2	8	1x4x100	13	16	20	42	25	48	40	126	97	34	88	20	22	22,000
650010	1/2	10	1x4x124	16	20	18	40	23	46	40	150	97	34	90	17	25	28,000
650012	1/2	12	1x4x148	19	24	16	38	21	44	40	174	97	34	94	13	28	33,000
650014	1/2	14	1x4x172	22	28	14	36	18	42	40	198	97	34	96	11	30	46,000
650016	1/2	16	1x4x196	25	31	12	34	15	40	40	222	100	36	98	9	32	61,000
650020	1/2	20	1x4x244	31	39	10	32	14	38	40	271	100	36	100	8	33	85,000

Specifications are subject to change without notice. Capacities are based on 80,000 tensile/44,000 yield strength steel.

# Accurshear 6625 | 6750 | 61000 SERIES

**5/8" 3/4" 1" CAPACITY**

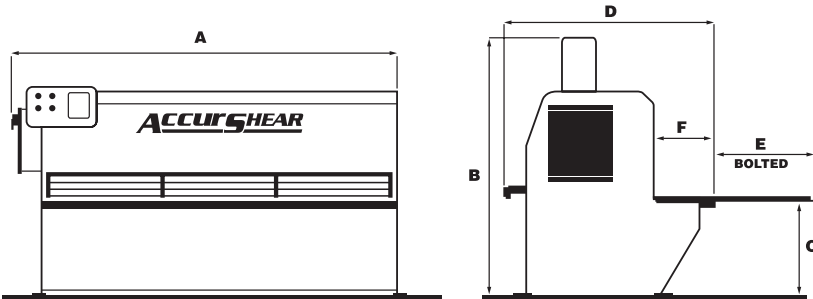

## Standard Features

- Shear capacity up to 80,000 tensile and 44,000 yield strength.
- Pendant control c/w on/off buttons, mode selector switch, and stroke control dial.
- Backgauge control includes LED display, inch or metric conversion, go-to-position function, 999 pre-select programs, hour meter and stroke counter.
- 48" backgauge travel with automatic swing up backstop at full extension.
- Mechanical Point of Operation Guarding applicable to OSHA and ANSI regulations.
- 4-edged blades, top, and bottom, modified high carbon, high chrome.
- 3 position footswitch control.
- 4' squaring arm c/w steel rule with 1/16" and 1 mm increments.
- Power blade clearance adjustment.
- Shadow light and line.
- Hand slots in table.
- T-slot in front of table.
- Ball transfers in table.
- Oil cooler.

MODEL NUMBER	CAPACITY INCHES	LENGTH FEET	KNIFE SIZE INCHES	NUMBER OF HOLD DOWNS	HOLD DOWN TONNAGE	CYCLES PER MINUTE		OPTIONAL HI-SPEED		MOTOR H.P.	OVERALL DIMENSIONS						APPROX. WEIGHT LBS.
						FULL STROKE	SHORT STROKE	FULL STROKE	SHORT STROKE		A	B	C	D	E	F	
662510	5/8	10	1½x5x124	16	32	14	35	18	40	50	153	105	36	105	16	24	38,000
662512	5/8	12	1½x5x148	19	38	12	32	16	37	50	177	105	36	107	14	26	45,000
662514	5/8	14	1½x5x172	22	44	11	29	14	34	50	201	105	36	109	12	28	59,000
662516	5/8	16	1½x5x196	26	52	9	25	12	31	50	225	106	36	110	11	29	68,000
662520	5/8	20	1½x5x244	30	60	7	21	9	27	50	274	110	38	111	10	30	90,000
675010	3/4	10	1½x5½x124	16	38	14	35	18	40	60	153	106	36	106	15	25	41,000
675012	3/4	12	1½x5½x148	19	45	12	32	16	37	60	177	106	36	108	13	27	47,000
675014	3/4	14	1½x5½x172	22	52	11	29	14	34	60	201	106	36	110	11	29	61,000
675016	3/4	16	1½x5½x196	26	62	9	25	12	31	60	225	106	38	111	10	30	78,000
675020	3/4	20	1½x5½x244	30	72	7	21	9	27	60	274	110	38	112	9	31	101,000
6100010	1	10	1½x5½x125	16	46	11	25	13	30	75	156	115	38	110	11	29	65,000
6100012	1	12	1½x5½x149	19	54	9	23	11	27	75	180	115	38	112	9	31	71,000
6100016	1	18	1½x5½x197	26	75	7	20	9	24	75	229	120	38	114	7	33	100,000

Specifications are subject to change without notice. Capacities are based on 80,000 tensile/44,000 yield strength steel.

## Built with **INTEGRITY**

### UNIQUE HYDRA-MECHANICAL ROCKER ARM DRIVE SYSTEM

This design, unique to the Accurshear, delivers the strength, power, and rigidity of the guillotine system and produces the ease of blade clearance adjustment afforded by the swing link design. The hydra-mechanical design utilizes two hydraulic cylinders, interconnected by a thick-walled torque tube, to provide the shearing force of the ram. Like the guillotine design, the Accurshear produces a cutting motion through the material that allows the use of 4-edged blades and a 1-degree relief angle.

### LOWEST FIXED RAKE ANGLES

The amount of bow and twist produced on a sheared piece of metal is directly related to the rake angle of the shear. Higher rake angles will produce greater amounts of these distortions in the metal. Accurshears are manufactured with extremely low rake angles to ensure optimum shearing quality with minimum distortions in all gauges of metal.

Model #	Rake Angle
6135	3/16" per ft.
6250	1/4" per ft.
6375	5/16" per ft.
6500	3/8" per ft.
6625	3/8" per ft.
6750	7/16" per ft.
61000	1/2" per ft.

### HIGHEST SHEARING RATING CAPACITIES

All Accurshear models are rated to shear structural quality steel with typical mechanical properties up to 80,000 tensile and 44,000 yield strengths.

### ULTRA-HEAVY FRAME STRUCTURE

The Accurshear is designed with a fully welded boxed-in bed table structure that has a high torsion stiffness to balance the torsion load from the cutting force. The maximum rigidity of the unique design, combined with the massive table design, ensures constant blade clearance during the shearing cycle. Blade clearances as low as .002" can be maintained through the entire cut, producing quality shearing on light gauge material. A machined table surface provides a generous, flat work area, and features finger wells to aid in lifting sheets.

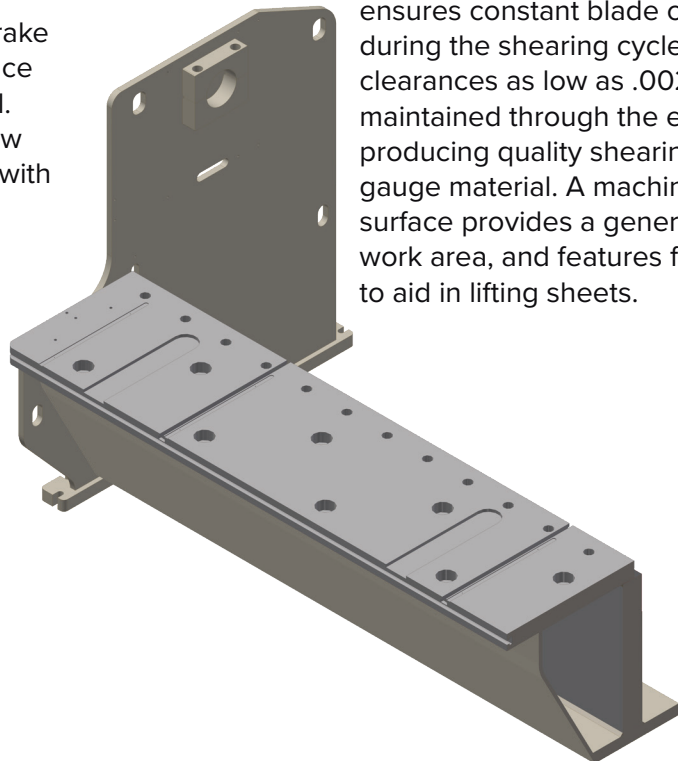



# Built with **WORLD RENOWNED** Components

## MAINTENANCE-FREE BEARINGS

Bearings installed in the Accurshear are of the highest quality, spherical, self-aligning and are zero clearance fitted on hard chrome shafts. The bearings are there for the long term, helping to ensure that the Accurshear will be precisely cutting metal for several decades.

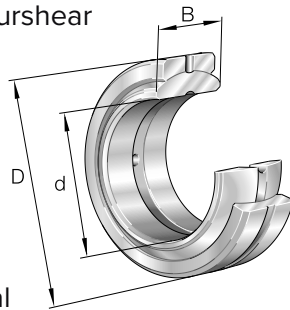

## QUALITY HYDRAULICS

The hydraulic reservoir, fitted with motor, pump, valves, filters, and cooler is designed for maximum efficiency and power. The unit is installed above the ram stiffener for ease of accessibility. A safety hydraulic relief valve is included to protect the Accurshear from overload. Each hydraulic cylinder is made of honed seamless tubing along with chrome-plated cylinder rods, assembled and tested at the Accurshear factory for quality assurance prior to installation. Additionally, the hold down clamps are made of induction hardened and chrome plated rods and are positioned on the Accurshear at 8" centers along the entire cutting length of the shear. Close spacing of hold downs is critical to ensure maximum force is applied to prevent movement of materials, and elimination of twisting or bulging of light gauge metals between the hold downs during the shearing process.

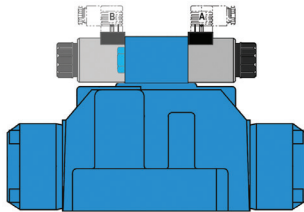

## ELECTRICAL COMPONENTS

Schneider Electric and Sprecher & Schuh, both worldwide leaders in power systems, are the primary suppliers for the Accurshear when it comes to electrical components. Their products—relays, starters, switches, contractors—are designed to meet and exceed robust industrial environments, providing the necessary key assurances for sustainability and long part life that is built into every Accurshear.

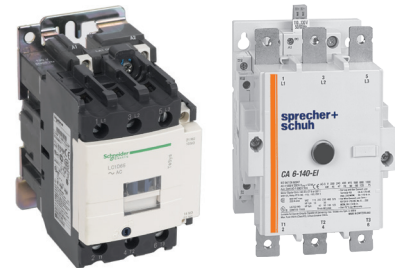

## SHEAR BLADES

The Accurshear comes with the highest quality shear blades available, made of high carbon, high chrome and shock resisting composition, suited to shear a wide variety of materials. The OPTIONAL D2 blade is available and recommended for the 61356 through 625024 models when shearing higher tensile and yield materials up to and including 10-gauge in thickness. Blade sharpness is maintained longer to ensure maximum shearing quality over an extended time.

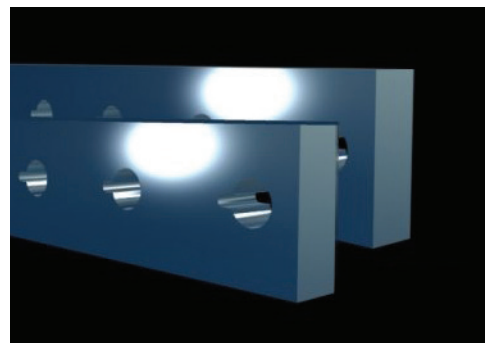

## PRODUCTIVITY Features

### STANDARD MF MACHINE CONTROL CONSOLE

The Accurshear MF Control uses standard electrical buttons and switches with a tactile input pad to allow users a common industrial control to manage the machine operations.



### OPTIONAL VISION MACHINE CONTROL CONSOLE

The Accurshear VISION Control uses an advanced technology to input commands via a touch screen interface providing efficiency and management in programming and machine operation flexibility.



### Display Features - MF Control

- 1 Mode Selector Switch: Jog, Manual, Auto
- 2 Stroke Length Control
- 3 LED readout/Data entry in .001" increments
- 4 Stroke counter, Hour meter, Inch/metric conversion Backgauge Calibration
- 5 999 pre-select backgauge settings Programmable single-step, sequential shearing
- 6 Go-to-Position Key
- 7 Go-to "pre-selected" backgauge position
- 8 Backgauge retract—On/Hold



The Standard console mounts and rotates on a pendant arm protruding from the side of the machine. An OPTIONAL SWING-AWAY PENDENT ARM is also available to provide more flexibility for operations requiring the console to be positioned further to the side of the shear.

### VISION Control

- Simple Touchscreen interactions to all functionality
- Create and Recall programs for Shear operations
- Multistep or Single cut programs
- Stroke counter, preset job counts, Inch/metric measure
- User interface prompts
- Preprogramming material information
- Plain language Error Message displays



## SQUARING ARM ASSISTS ACCURATE CUTTING

Located on the left end of the table is the 4' squaring arm with a steel rule measuring in 1/16" as well as 1 mm increments. Each arm includes a flip-up stop that may be locked into a set position. The recessed scale in the squaring arm measures from the cut line.

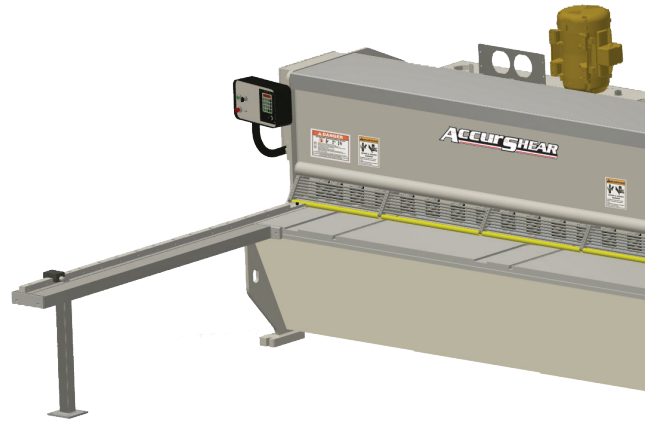
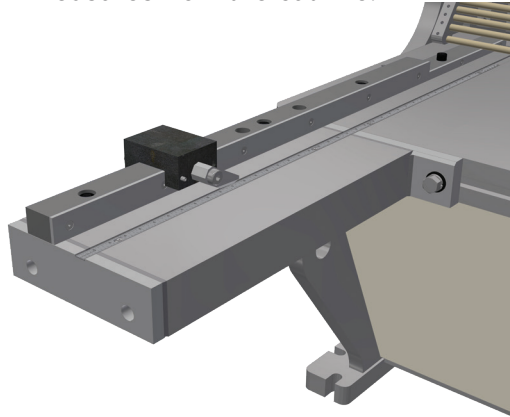

The Accurshear may be purchased with OPTIONAL extended squaring arm lengths of 6', 8', 10' and 12' as measured from the cut line.

## HEAVY-DUTY BACKGAUGE / SWING-UP BACKSTOP

A solid mechanical gauge constructed with large ACME lead screws and running on low-friction roller bearings provide consistent accuracies along with longevity and many years of low maintenance. Accurshear 6135xx-6500xx models come STANDARD with a 36-in travel. An OPTIONAL 48-in backgauge is available, and is included on 6625xx and larger models. The backstop bar on the Accurshear gauge will automatically swing-up once the full 36 or 48-inch distance is reached to allow for the shearing of longer pieces without restriction.



## BLADE CLEARANCE ADJUSTMENT

Accurshear 6250xxx-650012 models come with a MANUAL blade clearance adjustment lever on the side of the machine that permits for ease in setting the clearances for optimal shearing quality. Accurshear 6135xx models have a FIXED clearance setting due to minimal distances of approximately 0.002" required for lightgauge shearing.

### POWER BLADE CLEARANCE ADJUSTMENT

A POWERED blade clearance adjustment is available as an option for the 6250xx-650012 models, and is a STANDARD feature for 650014 and larger models. Control for the powered adjustment can occur with either the MF Control or VISION Control Consoles.



## OPTIONAL Features

### BALL TRANSFERS IN TABLE

Ball transfers mounted in the table are a standard feature on all Accurshear models 6500 and larger. They assist the movement of heavy materials over the table surface and may be ordered as an option on 6135, 6250, and 6375 series models.

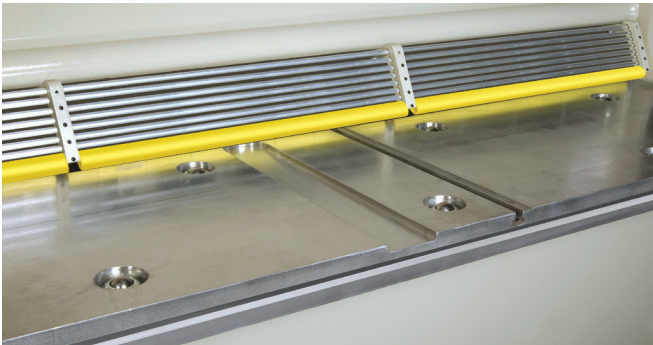

### FRONT ARMS

Front arms are available in 2', 4', and 6' lengths measured from the front of the shear table. Each arm is machined with a t-slot to accommodate a disappearing stop. Recessed scales may also be purchased for the front support arm to aid in front gauging. Ball transfers may be added to assist in the handling of large plates.

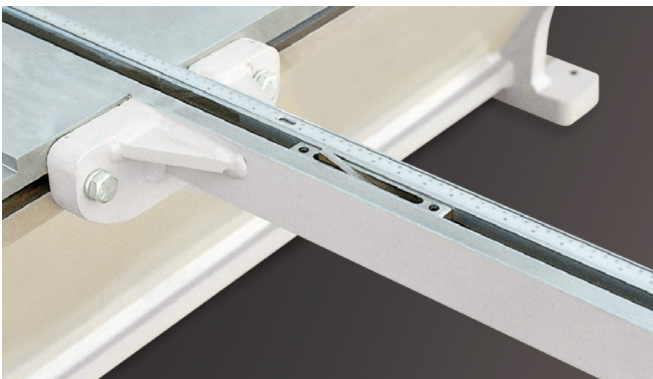

### HOLD DOWN PRESSURE CONTROL

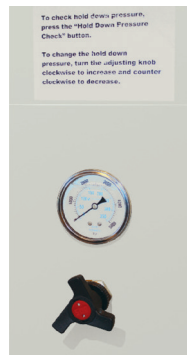

Some sensitive materials may experience marking under standard hold down pressures. This optional hold down pressure control provides pressure adjustment from 0 to 3,000 psi and is easily adjusted from the operator's normal work station.

### HIGH SPEED HYDRAULIC PACKAGE

This system offers approximately 30% faster cycle times than the standard package. Horsepower and pump volumes increase with this option. This option is not available for the 6135 series models.

### HOLD DOWN PADS

Hold downs can be equipped with urethane pads to reduce marking of aluminum or other sensitive materials.

### PROTRACTOR ALLOWS SPECIFIC ANGLE CUTS

The protractor bolts to the face of the table and can be positioned anywhere along its length. This versatility assists in accurately cutting specific angles, and can serve as a mobile squaring arm.

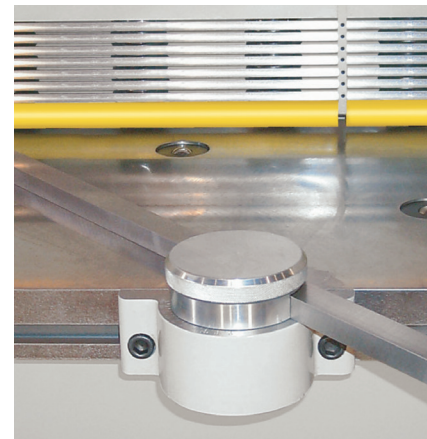

# SAFETY GUARDING Recommendations

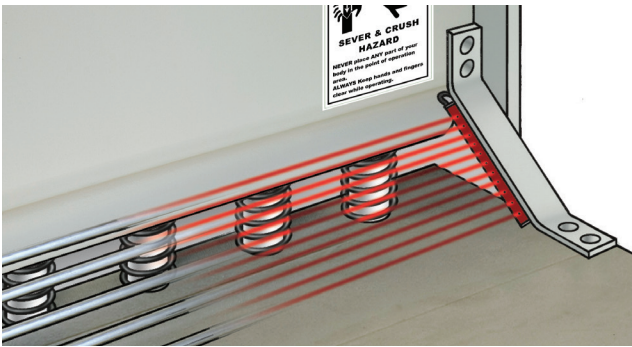

## LIGHT CURTAIN GUARDING

To enhance safety and allow an operator to position smaller pieces of metal into position for shearing, a light curtain may be purchased to replace the mechanical finger guard.

The Accurshear will not cycle or will stop abruptly if a foreign object interferes with the light curtain beam. The safety light curtain system satisfies the appropriate OSHA and ANSI regulations for safe operating conditions.

## REAR GUARDING

To facilitate safe operating conditions, Accurpress also offers guarding at the back of the shear. The mechanical guarding incorporates a light curtain beam, when interrupted will cause the shear to stop.

A mechanical rear guard with light curtain beams may also be purchased for Accurshears that include optional pneumatic Sheet Support systems or the Accurveyor/Stacker system. In such cases, the guarding extends beyond the furthest point of the OPTIONAL accessory to provide maximum safe operating conditions to adhere to OSHA and ANSI applicable standards.

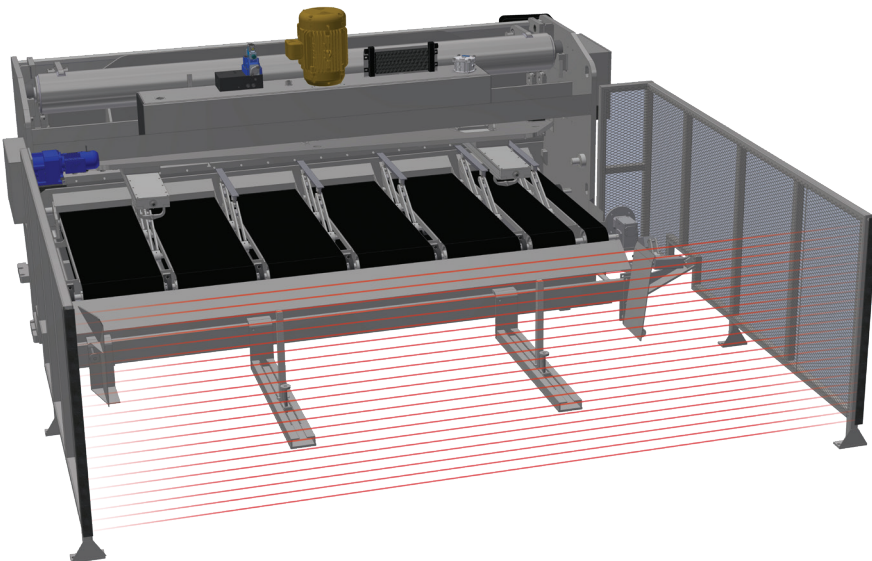
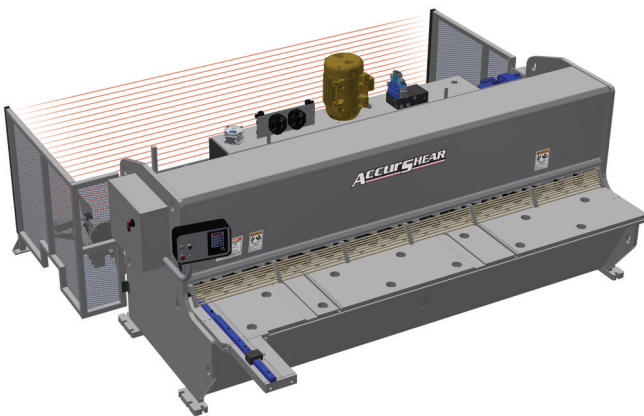

## SHEET SUPPORT Systems

### PNEUMATIC SHEET SUPPORT

A sheet support system is a recommended option for providing an accurate cut dimension. Light gauge material will quickly droop once it is pushed very far from the shear knife-edge—and consequently, the dimension on the drop off piece will not be consistent with the backgauge readout. Two styles are offered and both simply roll in under the shear ram and are operated via pneumatic power and an electronic circuit.



#### Table Style

The table style is recommended when support is necessary for very light gauge material and is offered on Accurshear 61356-625020 models. It consists of a table that rises parallel to the bottom of the backstop bar to support the material for accurate measurements. Once the hold downs clamp the metal, just prior to the shear cycle, the table automatically lowers itself, allowing the material to slide off. Once this is complete, the table rises to the “up” position again in preparation for the next cut.



#### Arm Style

This system incorporates three rows of arms that are in the “up” position prior to the shear cycle. They support the material parallel to the gauge bar for accurate measurement with the exception of 20 gauge and lighter gauges (table style recommended). Once the hold downs clamp the material, just prior to the shear cycle, the arms fall, allowing the material to slide off the table. After the cut is completed, the arms immediately rise to the up position in preparation for the next cut. Either support system can be turned on or off at any time by using the select switch on the control console.

### ROLLER TABLE

The non-powered roller table is an excellent option to help in the removal of sheared metal. The table is manufactured in various lengths and is positioned under the Accurshear ram to enable sheared pieces to roll to the back of the shear via the heavy-duty rollers for quick and easy access. Elimination of the awkward removal of sheared pieces that typically fall directly under the ram greatly increases shear efficiency and reduces cycle time.

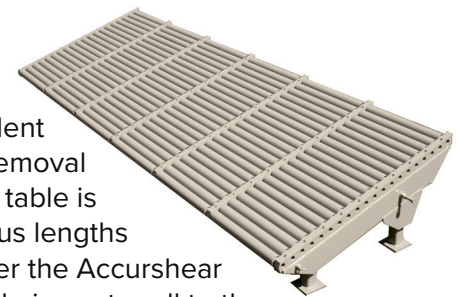

# ACCURVEYOR/STACKER Systems



Conveyor  
stop/start

Scrap door  
open/close

Sheet support  
on/off

## WORK SUPPORT ARMS

- Improves accuracy because the sheet is supported parallel to the table.
- Eliminates the need to manually support light-gauge sheets from behind the machine.
- Holding material level with the shear table enables accurate backgauge readings.
- The supports drop systematically with the shear cycle thus holding the material and reducing plate tear.

## TRIM CUT SEPARATOR

- Separates edge trim from production blanks.
- Opens via the conveyor foot switch or front console button.

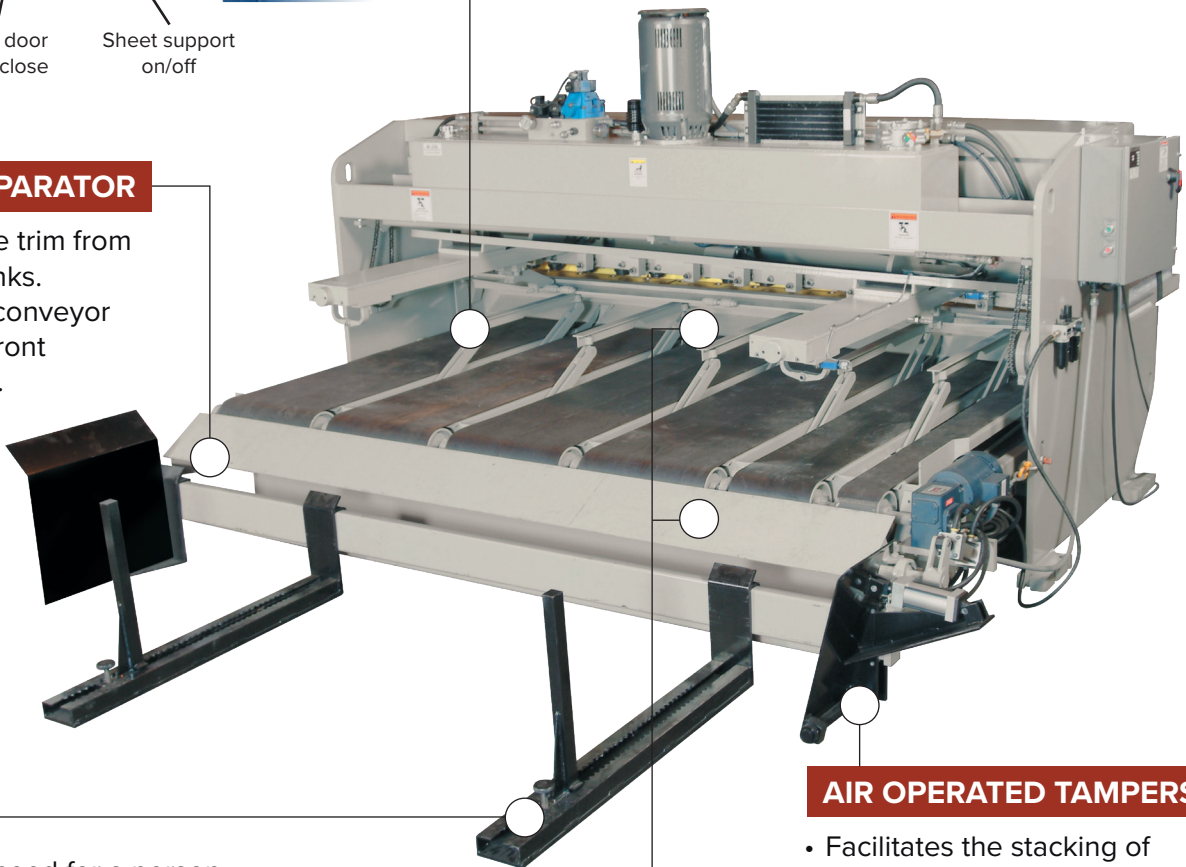

## STACKER

- Eliminates the need for a person behind the shear to do the stacking.
- Stacks the material neatly for removal by an overhead crane, fork truck or pallet jack.

## AIR OPERATED TAMPERS

- Facilitates the stacking of sheared pieces.

## URETHANE PROTECTION

- Urethane pads are available as an added OPTION and secured to the top of the arms and the scrap door.
- Provides the most adequate protection for sensitive materials that may be prone to scratching during the conveying process.

## Accurshear **CNC FRONTGAUGE**

### CNC CONTROL

Allows for both frontgauge and backgauge operation.



### 1/4" x 10' shearing capacity

With heavy-duty CNC frontgauge

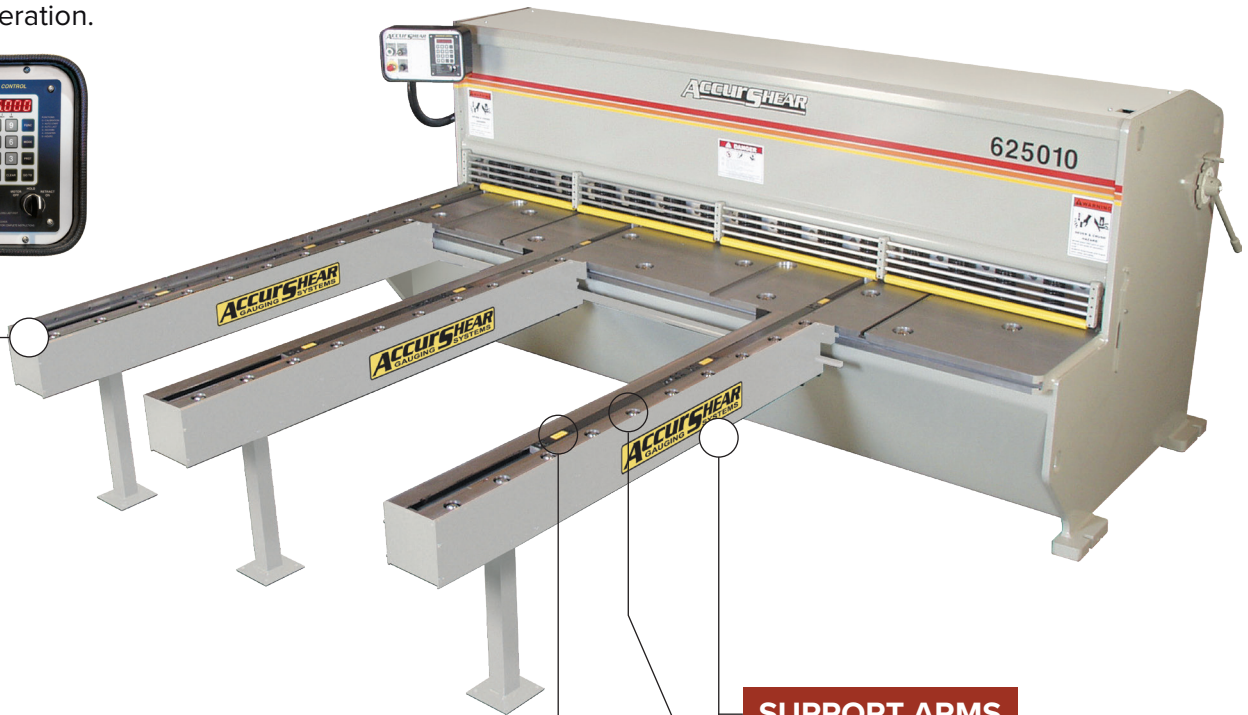

### SQUARING ARMS

Available in 8', 10', 12' lengths:

- Squares material for accurate shearing.
- Can be installed on either left or right side.
- Contains ball transfers and recessed ruler.

### PNEUMATIC FINGER STOPS

1" wide, air-activated finger raises at gauging position to avoid scratching of the work piece.



### SUPPORT ARMS

Available in 6', 8', 10' lengths.

### STANDARD BALL TRANSFERS

Enables the movement of heavy materials.

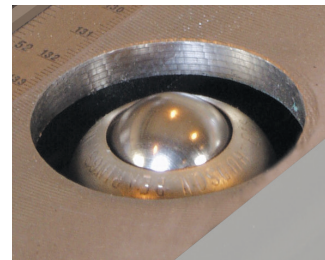





**5/8" x 20' shearing capacity**

With heavy-duty CNC frontgauge

### ACCURACY

- +/- .003" positioning accuracy
- High accuracies achieved with precision ball screws

### PRODUCTIVITY ADVANTAGES

- Maximizes material usage
- Reduces handling and thereby increases efficiency
- Substantially increases shearing accuracy
- Reduces personnel needs
- Eliminate problems associated with sheet sag when measuring via a backgauge
- Drive system operates at over 900 in/min
- Easy mechanical adjustment for calibration

## SPECIAL Applications/SPECIAL Machines

From small shears to large, Accurpress can build a shear to suit your needs.

We specialize in producing equipment that will meet the shearing needs found within the vast array of sheet metal and heavy fabrication shops throughout North America. Whether you are shearing light gauge and sensitive metals or heavy steel—job shop to high production volume, the Accurshear is the answer.



3/4" x 10' shearing capacity

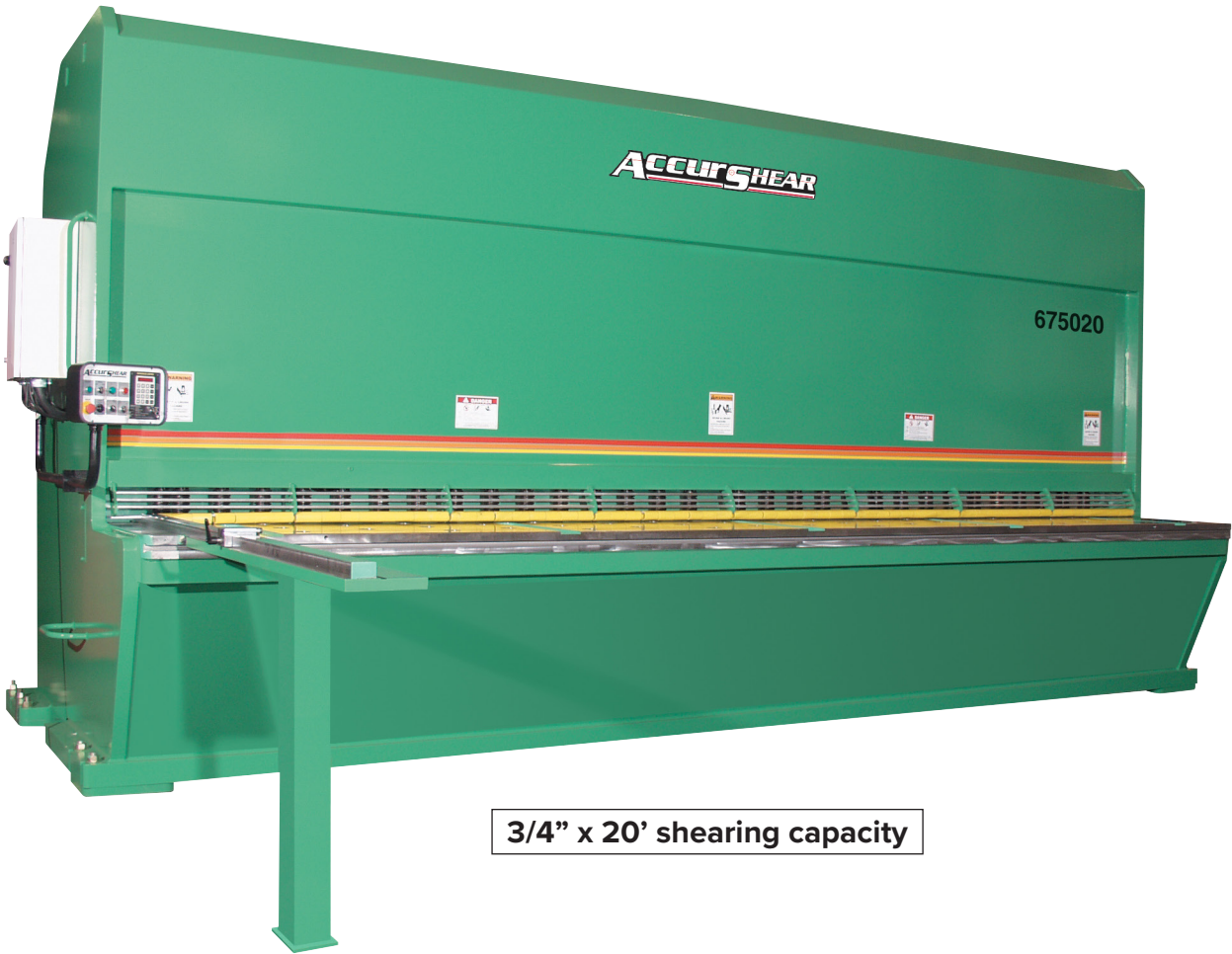

**NO JOB IS TOO BIG FOR ACCURPRESS!**

## Dealer Support Network

Accurpress Sales & Service is provided by an Authorized Dealer Network. All of our Dealers are factory trained and supported to provide you with knowledgeable, competent, and local service.



© Copyright June 2020

For more information about our products, please refer to our comprehensive brochures or visit our site [www.accurpress.com](http://www.accurpress.com).

**ACCURPRESS**



Tel. 55 2121 9181  
y 55 2121 9194

Soporte & Desarrollo  
en Maquinaria